



# Residential Security

**Columbus Police  
Community Liaison  
Section**

## The Burglary Threat

Residential burglary is a national, rapidly growing, costly and potentially dangerous crime that can lead to other crimes. When your home is burglarized, you'll probably lose a radio, TV, stereo, camera or jewelry. But more importantly, you will also lose your peace of mind, and the sense of safety your home brought to you. Additionally, the safety and welfare of your family may be jeopardized!

Many people believe house burglars are professional criminals, experts at defeating the most elaborate security measures. Yet, in most cases, residential burglary is a crime of opportunity committed by young amateurs who look for easy targets, like poorly secured homes or homes that look unoccupied. You can lessen the opportunity and minimize the chance of burglary by making your home as difficult as possible to enter. All that is needed is a little effort to take the preventative steps recommended in this booklet!

The quality of hardware and preventative measures described on the following pages will deter, delay and help to detect a burglar. This will increase the chance of an alert neighbor or area police officer observing the thief resulting in his or her arrest.

The time to install this hardware is **NOW**, not after a burglary has occurred!

Don't forget that burglary prevention goes beyond good locks and household security. It includes being a good neighbor and reporting any suspicious activity, person or vehicle to the police. Neighborhood security requires neighborhood cooperation.

# Neighborhood Blockwatch

If properly organized and actively supported, neighborhood Blockwatches are a proven means of reducing burglary and other typical street crimes. The objective is to have neighbors watch for emergencies or unusual behavior and report them to the police.

Blockwatch members are trained by police to identify and report suspicious or criminal behavior. To organize a Blockwatch group, call the Columbus Division of Police, Crime Prevention Unit at 645-4610.

## Operation Identification

If you are the victim of a burglary or other crime, the chances of your property being recovered and returned are greatly increased if your possessions have been "personalized." Engrave your initials and/or partial social security number along with an "OH" prefix on the back (metal) plates of your appliances, stereo, TV, etc. Items that cannot be engraved (jewelry, antiques, firearms and heirlooms) should be photographed and regularly appraised for accurate value. There are two pages provided in this booklet for recording such information.



Here is what you can do outside your home to make it less appealing to burglars.

1. Trim shrubs so windows and doors are in full view from the street. A good rule of thumb is no plantings taller than 3' or hanging lower than 7'. Unobstructed doors and windows are a deterrent because the intruder is forced to work in the open where detection is more likely.
2. Maintain (and use) adequate lighting, especially at entry points. The power company will install a yard / alley light for a reasonable monthly charge.
3. Don't leave ladders and tools lying around outside where burglars can use them to enter your home.
4. All valuables like lawn mowers and bicycles should be locked in your garage or shed.
5. Always keep your garage doors closed and locked. This prevents burglars from entering your home through the door leading from your garage into your home. Additionally, it takes only seconds to walk into an open garage to steal work and yard tools.
6. House numbers should be large, prominently displayed and well lighted to insure they can be **easily** read from the street. This helps police and other emergency vehicles find your home in an emergency. Urge your neighbors to do the same.



## What About Burglar Alarms?

A properly installed, quality alarm system can significantly improve your overall security, however, alarm systems can be expensive for a private residence. A complete system, including 24 hour monitoring service, can run from a few hundred to several thousand dollars depending upon what you wish the system to do for you. Monthly monitoring service fees average from about \$ 15.00 to \$ 25.00. You can forego a central station hookup for a less expensive alarm system that will simply make a lot of racket when a burglar attempts to enter your home or garage. These are known as "local" or "audible" alarms and depend upon a neighbor hearing the alarm and notifying the police. Here are a few tips on shopping for alarm systems.

1. Keep it as simple as appropriate. Avoid extremely elaborate systems requiring constant maintenance just to stay in operation. However, be sure to include smoke/heat detectors as part of your installation!
2. Avoid extra "gadget" accessories or systems with complicated on/off procedures. Setting the system should require little more than turning a key or pushing a few buttons on a key pad.

3. Ensure that your alarm system features emergency back-up battery power in the event of electrical failure.
4. As a general rule, it is strongly recommended that all residential systems have an audible signal device (usually a siren), whether monitored or not. Ideally, audible signal devices should be used inside and out.
5. **SHOP CAREFULLY!** Get two or more estimates. Feel free to call our office for answers to general questions about alarm systems.
6. As with any major purchase, check for service after the sale. Know what will be involved in maintaining your system before you purchase it. Check with other customers and/or the Better Business Bureau to check for unresolved complaints.
7. Ensure that all family members have a basic understanding of the system. The biggest cause of false alarms is user error.
8. Be sure to contact the Columbus License Bureau to obtain an alarm license (required for ALL systems) at 645-8366.



# Entry Doors

Many residential doors are of the hollow core construction, thin wood veneer with nothing but cardboard fill. You can literally put your fist through one. Such doors are designed for interior use only, such as for bedrooms or closets. Exterior doors should be of solid wood or metal sheath construction. But whatever the door makeup, most burglars look for inadequate locking devices, like the ones below:

## Spring Latch

Most doors come equipped with a spring latch, like the one you see here. It offers *No* protection, and can be slipped or "shimmed" with a credit card or penknife.

The same lock, with a deadlatch or anti-shim device, prevents slipping. But it still can be forced, or the door spread from the frame.

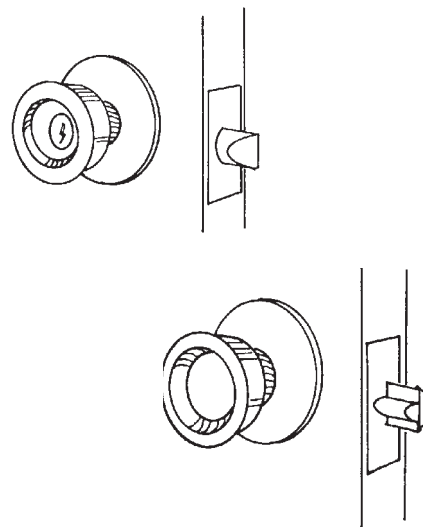

## Deadbolts

A deadbolt lock offers the best security. When you turn the key, a strong metal bolt slides out of the door and into the frame.

### Single Cylinder Deadbolt

This deadbolt requires the use of a key from the outside, with a plain thumbturn on the inside.

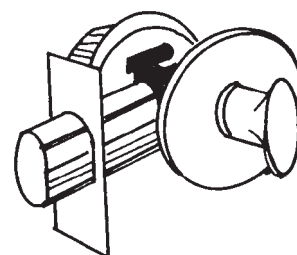

### Double Cylinder Deadbolt

This deadbolt requires the use of a key from both sides of the door, and boasts two principal advantages over the single cylinder lock: First, a burglar can't simply break out a pane of glass, reach in and flip a thumb turn; second, if he does get in by other means, such as through a window, a door secured with a double cylinder deadbolt will be unavailable for removal of large items. His "take" will be limited to what he can fit through the window.

Many people are concerned about the fire hazard created through the use of double cylinder deadbolts. For this reason:

1. Keep an extra key close by the door in case of emergency.
2. Install smoke detectors in your home and keep them in working order.
3. Develop a family plan for emergency exit.

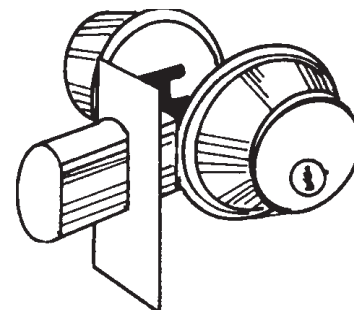

*You Can have both fire and burglary protection!*

# Overhead Garage Doors

For long range protection of overhead doors, such as during vacations or weekend trips, affix an inexpensive padlock to the inside frame. That way the door cannot be raised even if the door lock is broken.

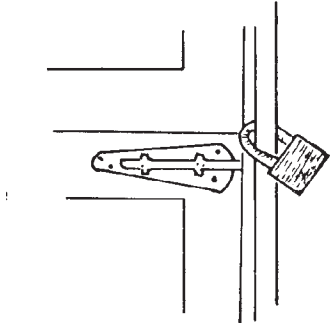

## Hasps

No padlock is better than the hasp on which it is mounted. A good hasp is made of hardened steel, and is constructed in such a way that bolt heads are not visible when the hasp is in the closed position.

Don't install a hasp with ordinary screws. Use long stove bolts which go completely through the door or gate.

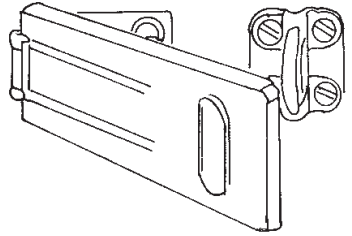

## Casement Windows

Casement windows are usually easy to secure. Be sure that the latch works properly, and that the operating mechanism has no excessive play. If the window is seldom used, the operating handle could be removed for extra security.

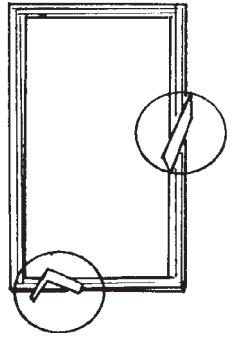

## Sliding Glass Doors

Charley-bars can be installed in minutes and block the moveable door in the closed position. These are more reliable than simply putting a broom handle in the channel.

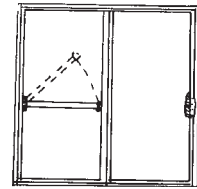

Auxiliary key locks, often of a plunger design as shown here, prevent the door from being moved even if the regular lock on the door is forced.

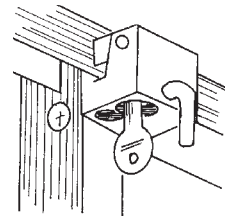

Prevent lifting of the sliding glass doors or windows off their channels by installing sheet metal screws in the upper track above

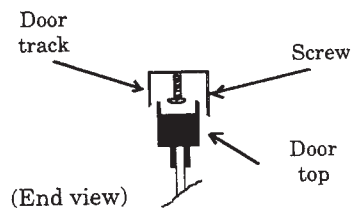

## Sliding Glass Doors *(continued)*

One additional consideration to increase the burglar resistance of sliding glass doors is to "pin" the doors. This is an easy and inexpensive process which consists of drilling a small, downward angled hole at the top center of the door's frame through one door section into the other. This is done where the moving (sliding) portion of the door assembly overlaps the stationary section of the door assembly. Then, insert a steel pin or heavy nail into the hole. **Be careful to avoid drilling too close to the glass area of the doors!**

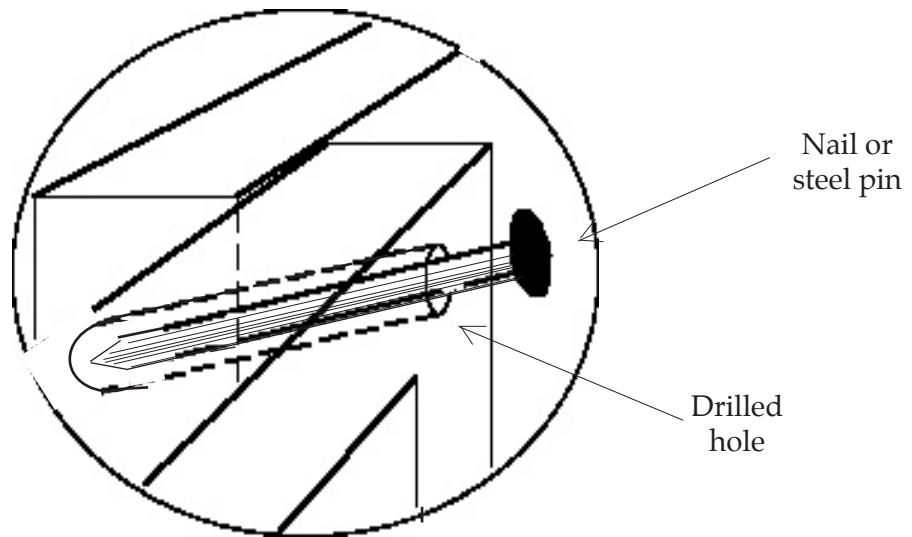

Lastly, you can place a length of wood in the lower track of your sliding glass door. Make certain that it fits snugly and that it lays flat in the door track in order to prevent it being popped out of the track by an intruder.

## Safety at the Door

Remember... never open your door to a stranger. Always demand proper identification from salespeople or utility company employees. While this is common sense to adults, children must be continually reminded about this very important safety consideration. Keep in mind that chain locks are primarily a privacy device and should **never** be relied upon for maximum security. Consider installing a "peephole" exterior access doors to enable you to see who is there before opening any doors.

As previously stated, doors are the primary target of entry for most residential criminals. The various safety hardware, techniques and considerations will only help you to make your home safer if you **remember to use them!**

## Window Protection

Windows are second only to doors as the most inviting means of entry for the determined burglar.

### Double-Hung Windows

You can easily secure your double-hung wood sash windows by drilling a hole at the point where the two frames meet and inserting a dowel, heavy metal pin or nail. Make sure the hole goes all the way through the inner sash, but only partially through the outer sash. Drill the hole at a downward slanting angle, to resist dislodging the pin by shaking or vibration.

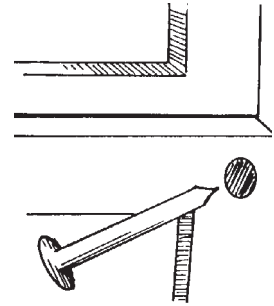

### Auxiliary Window Lock

Even more secure are the auxiliary keyed window locks, such as the plunger style pictured here. These locks prevent the window from being opened even if the glass is broken. Your lock smith can show you several different models of window locks for both metal and wood sash.

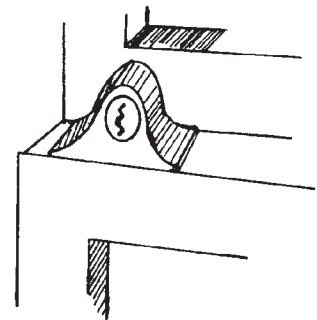

### Bars and Grillwork

Ornamental bars and grillwork are generally not recommended for first and second level windows because of the fire hazard they may create. If they must be used, they should feature a quick-release mechanism on the inside.

### Basement Windows

Basement windows are a favorite means of illegal entry, often due to their concealment. Since they are seldom needed as a fire exit, they can be effectively secured with inexpensive bars, as pictured here. Bars should be flat steel, three-sixteenths-inch by one and one-half-inch, and be mounted into the masonry with heavy bolts. There should be no more than six inches between bars.

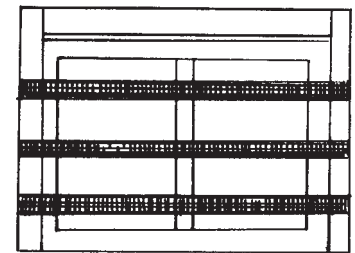

### Padlocks

Most households make use of one or two padlocks somewhere. A good one has the following features.

1. Heavy body or laminate construction
2. Toe and heel locking
3. Hardened steel shackle

Remember to erase or file off key numbers which may appear on the bottom of a padlock. Unauthorized keys can be made from this number.

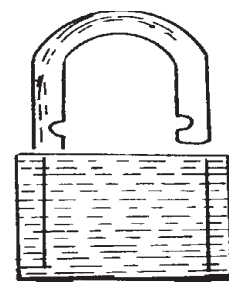

## Door Strikes and Frames

A deadbolt lock is no more effective than the striker plate and door frame it engages. Look for a snug fit between the lock and the striker plate. If your door strike is installed with small, half-inch screws, replace them with two and one-half to three-inch screws which anchor into the stud. This method adds considerable strength to your door.

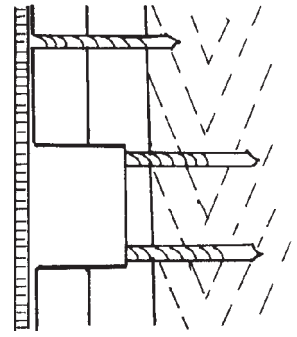

## Pinned Hinge

If your exterior doors swing out, the hinges are on the outside. A burglar can easily remove the hinge pins and lift or pry the door. This is easily prevented by removing the center screw from each side of the hinge and inserting a headless screw or dowel in one side.

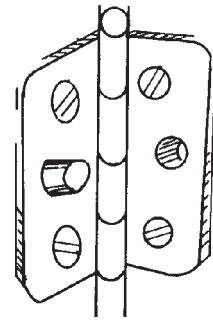

## Security for Double Doors

Double doors can be very difficult to secure, but not impossible. Many of these doors incorporate slide bolts mounted on the inactive door. These are weak and inadequate. For maximum security, install cane or flush bolts at the top and bottom, as shown here:

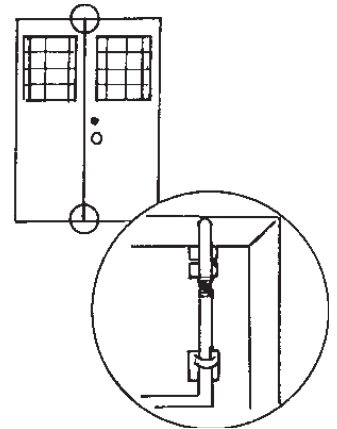

## Drop-Bolts

Drop-bolt devices, sometimes called vertical throw bolts, offer protection similar to conventional deadbolts. The bolt engages vertical pins in a receiving plate, and provides excellent security so long as it is installed on a strong door and frame.

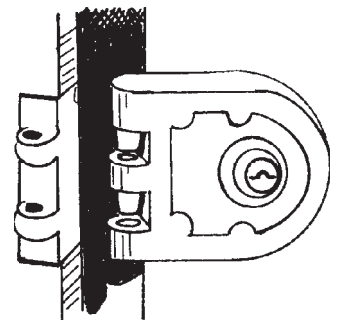



## Security Lighting

Since most burglars don't like to be observed while they are working, they often shun well lighted areas. A few exterior lights, mounted either on yard poles or beneath the eaves of your house and shining at a downward slanting angle, provide extra security and peace of mind. Avoid any type of lighting that causes glare in the direction of the street. Such lighting is counter-productive to security. Since you want cruiser patrols and passers-by to glance in the direction of your home, not away from it.

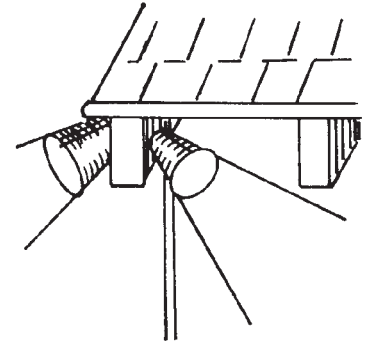

Keep shrubbery, trees, and other foliage away from windows and doors. They provide excellent coverage for a burglar to work without risk of detection.

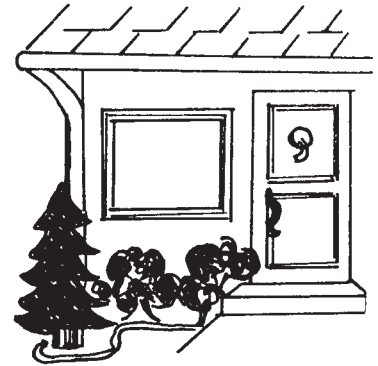

## Emergency Calls Dial "9-1-1"

**All other calls  
Dial 645-4545**

Prepared and presented as  
a service of the  
**Columbus Division of Police  
Community Liaison Section  
645-4610**



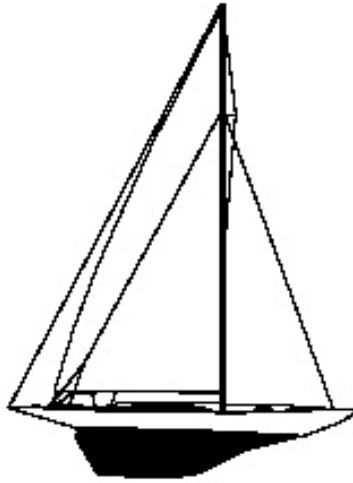

## **Taking a Vacation?**

Here is a Home Security Checklist.

1. Lock all doors and windows.
2. Leave all shades and blinds in their normal positions.
3. Advise a trusted neighbor of your travel plans and ask him/her to watch out for suspicious people and/or activity around your home and property.
4. Call the police department (in Columbus at 645-4717) for a vacation house watch. Provide them with emergency numbers, key holders and other security details and they will have a cruiser drive by periodically to check your property as time allows.
5. Don't allow deliveries of any kind to accumulate on your doorstep. If you do not wish to cancel deliveries, arrange for a neighbor to pick them up. Don't forget to have your mail held for your return or picked up by a neighbor.
6. Arrange for lawn mowing or snow shoveling at proper times.
7. Connect one or two lamps and perhaps a radio to an automatic timer. They are inexpensive and help to make your home appear "occupied".
8. Refrain from publicizing your exciting vacation or trip until after your return.

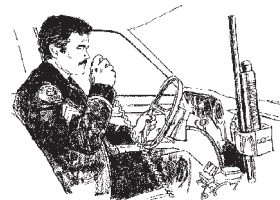

Use the following pages to inventory your appliances, tools, electronic equipment, cameras, jewelry and other valuables. Some other examples would include lawnmowers, VCR's, typewriters, computers, fishing equipment & guns.

Item Description	Make	Model	Serial Number

Item Description	Make	Model	Serial Number